



REPAIRING CLAMP WITH BILATERAL HEATING ZONE SDR 11



water
16 bar



gas
10 bar



hydrogen
10 bar



PE 100-RC
material



MRS 10 MPa



center welding
zones

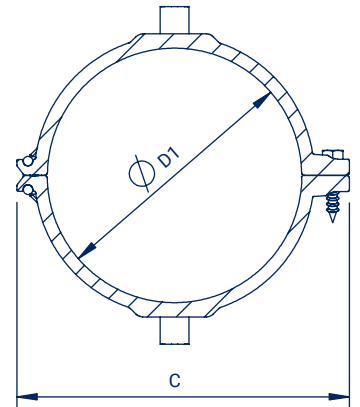
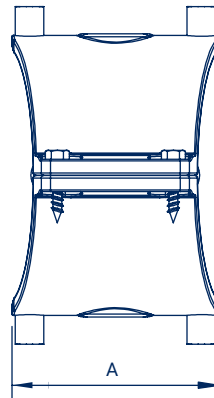

Size D1 (mm)	Code	A (mm)	C (mm)	Weight (kg)	Packing
63	OND06311	115	109	0,33	45
75	OND07511	117	123	0,38	30
90	OND09011	128	138	0,50	30
110	OND11011	128	162	0,56	20
125	OND12511	128	170	0,63	20
140	OND14011	127	180	0,54	20
160	OND16011	130	230	0,81	15
180	OND18011	130	239	0,97	12
200	OND20011	169	239	1,36	10
225	OND22511	169	239	1,38	10
250	OND25011	169	265	1,47	10
280	OND28011	169	267	1,46	10
315	OND31511	169	290	1,57	10