



SEAMLESS BEND 11°

SDR 17



water
10 bar



gas
5 bar



hydrogen
5 bar



PE 100-RC
material



MRS 10 MPa



butt
welding



electrofusion
welding

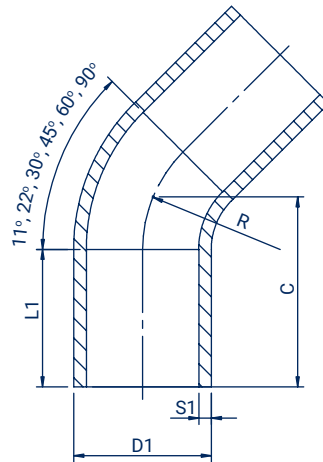

Size D1 (mm)	Code	L1 (mm)	C (mm)	S1 (mm)	R (mm)	Weight (kg)	Packing
63	LU1106317	90	150	3,8	94,5	0,22	1
75	LU1107517	100	155	4,5	112,5	0,26	1
90	LU1109017	150	350	5,4	135	0,98	1
110	LU1111017	120	219	6,6	165	1,10	1
125	LU1112517	150	225	7,4	187,5	1,46	1
140	LU1114017	150	231	8,3	210	2,04	1
160	LU1116017	150	239	9,5	240	2,48	1
180	LU1118017	150	450	10,7	270	5,08	1
200	LU1120017	150	480	11,9	300	6,70	1
225	LU1122517	150	510	13,4	338	9,11	1
250	LU1125017	250	540	14,8	375	11,99	1
280	LU1128017	250	400	16,6	420	12,68	1
315	LU1131517	250	460	18,7	472,5	17,70	1
355	LU1135517	300	540	21,1	532,5	26,22	1
400	LU1140017	300	560	23,7	600	29,80	1
450	LU1145017	300	580	26,7	675	39,10	1
500	LU1150017	350	650	29,7	750	61,80	1
560	LU1156017	350	680	33,2	840	82,00	1
630	LU1163017	350	730	37,4	945	95,80	1