



SEAMLESS BEND 30°

SDR 17



water
10 bar



gas
5 bar



hydrogen
5 bar



PE 100-RC
material



MRS 10 MPa



butt
welding



electrofusion
welding

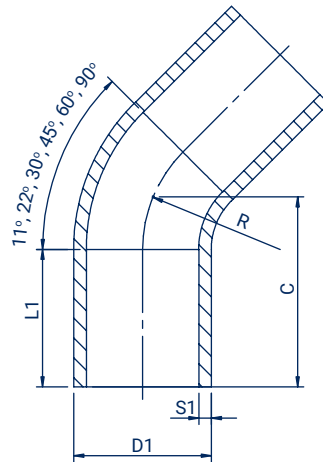

Size D1 (mm)	Code	L1 (mm)	C (mm)	S1 (mm)	R (mm)	Weight (kg)	Packing
63	LU3006317	90	150	3,8	94,5	0,25	1
75	LU3007517	100	155	4,5	112,5	0,39	1
90	LU3009017	150	350	5,4	135	0,98	1
110	LU3011017	120	219	6,6	165	1,18	1
125	LU3012517	150	225	7,4	187,5	1,46	1
140	LU3014017	150	231	8,3	210	1,80	1
160	LU3016017	150	239	9,5	240	2,56	1
180	LU3018017	150	450	10,7	270	5,08	1
200	LU3020017	150	480	11,9	300	6,70	1
225	LU3022517	150	520	13,4	338	9,11	1
250	LU3025017	250	560	14,8	375	11,99	1
280	LU3028017	250	400	16,6	420	13,60	1
315	LU3031517	250	460	18,7	472,5	17,70	1
355	LU3035517	300	540	21,1	532,5	26,00	1
400	LU3040017	300	560	23,7	600	29,80	1
450	LU3045017	300	580	26,7	675	39,10	1
500	LU3050017	350	650	29,7	750	61,80	1
560	LU3056017	350	680	33,2	840	83,00	1
630	LU3063017	350	730	37,4	945	95,80	1