



SEAMLESS BEND 90°

SDR 11



water
16 bar



gas
10 bar



hydrogen
10 bar



PE 100-RC
material



MRS 10 MPa



butt
welding



electrofusion
welding

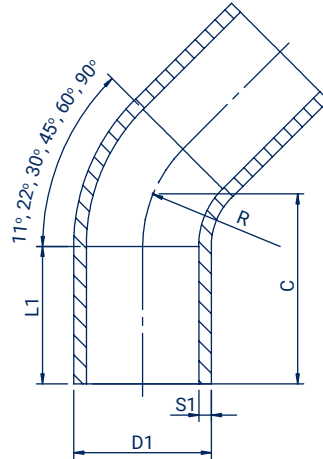

Size D1 (mm)	Code	L1 (mm)	C (mm)	S1 (mm)	R (mm)	Weight (kg)	Packing
32	LU9003211	70	133	2,9	48	0,08	1
40	LU9004011	75	150	3,7	60	0,14	1
50	LU9005011	80	185	4,6	75	0,28	1
63	LU9006311	90	220	5,8	94,5	0,45	1
75	LU9007511	100	238	6,8	112,5	0,65	1
90	LU9009011	150	380	8,2	135	1,28	1
110	LU9011011	120	315	10	165	1,87	1
125	LU9012511	150	470	11,4	188	2,88	1
140	LU9014011	150	385	12,7	210	3,72	1
160	LU9016011	150	550	14,6	240	5,72	1
180	LU9018011	150	590	16,4	270	8,51	1
200	LU9020011	150	650	18,2	300	10,19	1
225	LU9022511	150	675	20,5	338	13,85	1
250	LU9025011	250	780	22,7	375	22,82	1
280	LU9028011	250	695	25,4	420	24,30	1
315	LU9031511	250	803	28,6	472,5	36,80	1
355	LU9035511	180	560	32,2	532,5	34,03	1
400	LU9040011	300	980	36,3	600	75,00	1
450	LU9045011	195	645	40,9	675	69,12	1
500	LU9050011	212	710	45,4	750	91,04	1
560	LU9056011	350	1290	50,8	840	176,00	1
630	LU9063011	350	1400	57,2	945	239,00	1