



SEAMLESS BEND 90°

SDR 17



water
10 bar



gas
5 bar



hydrogen
5 bar



PE 100-RC
material



MRS 10 MPa



butt
welding



electrofusion
welding

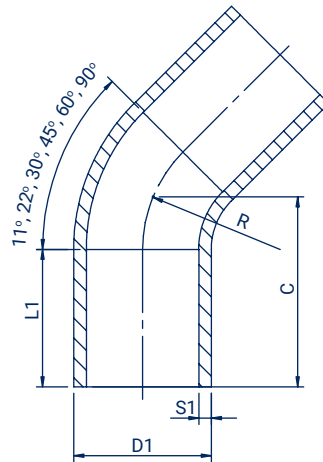

Size D1 (mm)	Code	L1 (mm)	C (mm)	S1 (mm)	R (mm)	Weight (kg)	Packing
63	LU9006317	90	220	3,8	94,5	0,32	1
75	LU9007517	100	238	4,5	112,5	0,46	1
90	LU9009017	150	380	5,4	135	0,88	1
110	LU9011017	120	340	6,6	165	1,24	1
125	LU9012517	150	363	7,4	187,5	1,90	1
140	LU9014017	150	385	8,3	210	2,66	1
160	LU9016017	150	415	9,5	240	3,36	1
180	LU9018017	150	590	10,7	270	5,77	1
200	LU9020017	150	650	11,9	300	7,10	1
225	LU9022517	150	675	13,4	338	9,39	1
250	LU9025017	250	650	14,8	375	12,50	1
280	LU9028017	250	695	16,6	420	17,10	1
315	LU9031517	250	803	18,7	472,5	25,00	1
355	LU9035517	300	900	21,1	532,5	41,22	1
400	LU9040017	300	980	23,7	600	49,70	1
450	LU9045017	195	645	26,7	675	50,72	1
500	LU9050017	212	710	29,7	750	66,94	1
560	LU9056017	350	1290	33,2	840	120,00	1
630	LU9063017	350	1400	37,4	945	169,00	1