



SEAMLESS BEND 45°

SDR 17



water
10 bar



gas
5 bar



hydrogen
5 bar



PE 100-RC
material



MRS 10 MPa



butt
welding



electrofusion
welding

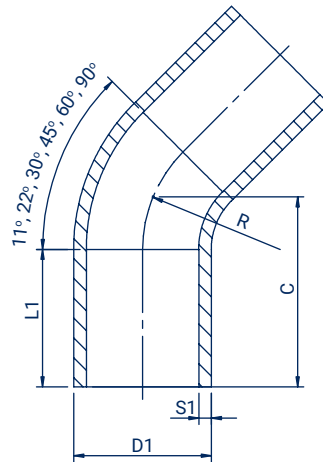

Size D1 (mm)	Code	L1 (mm)	C (mm)	S1 (mm)	R (mm)	Weight (kg)	Packing
63	LU4506317	90	161	3,8	94,5	0,30	1
75	LU4507517	100	168	4,5	112,5	0,40	1
90	LU4509017	150	350	5,4	135	0,98	1
110	LU4511017	120	243	6,6	165	1,22	1
125	LU4512517	150	253	7,4	187,5	1,60	1
140	LU4514017	150	262	8,3	210	1,94	1
160	LU4516017	150	274	9,5	240	2,75	1
180	LU4518017	150	460	10,7	270	5,08	1
200	LU4520017	150	495	11,9	300	6,70	1
225	LU4522517	150	525	13,4	338	9,11	1
250	LU4525017	250	570	14,8	375	11,99	1
280	LU4528017	250	460	16,6	420	13,60	1
315	LU4531517	250	535	18,7	472,5	20,00	1
355	LU4535517	300	620	21,1	532,5	28,50	1
400	LU4540017	300	650	23,7	600	37,00	1
450	LU4545017	300	680	26,7	675	45,30	1
500	LU4550017	350	760	29,7	750	78,00	1
560	LU4556017	350	800	33,2	840	93,00	1
630	LU4563017	350	870	37,4	945	128,00	1