



# SEAMLESS BEND 45°

## SDR 11



water  
16 bar



gas  
10 bar



hydrogen  
10 bar



PE 100-RC  
material



MRS 10 MPa



butt  
welding



electrofusion  
welding

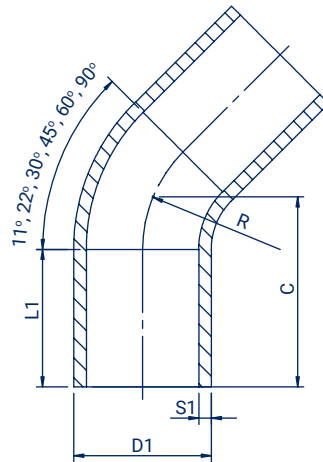

Size D1 (mm)	Code	L1 (mm)	C (mm)	S1 (mm)	R (mm)	Weight (kg)	Packing
32	LU4503211	70	105	2,9	48	0,07	1
40	LU4504011	75	110	3,7	60	0,11	1
50	LU4505011	80	139	4,6	75	0,22	1
63	LU4506311	90	161	5,8	94,5	0,38	1
75	LU4507511	100	168	6,8	112,5	0,54	1
90	LU4509011	150	350	8,2	135	1,42	1
110	LU4511011	150	340	10	165	2,07	1
125	LU4512511	150	380	11,4	188	3,06	1
140	LU4514011	150	405	12,7	210	3,96	1
160	LU4516011	150	425	14,6	240	5,54	1
180	LU4518011	150	460	16,4	270	7,49	1
200	LU4520011	150	495	18,2	300	9,88	1
225	LU4522511	150	525	20,5	338	13,36	1
250	LU4525011	250	570	22,7	375	17,66	1
280	LU4528011	250	460	25,4	420	20,05	1
315	LU4531511	250	535	28,6	472,5	29,28	1
355	LU4535511	300	620	32,2	532,5	42,20	1
400	LU4540011	300	650	36,3	600	56,00	1
450	LU4545011	300	680	40,9	675	69,80	1
500	LU4550011	350	760	45,4	750	102,40	1
560	LU4556011	350	800	50,8	840	141,00	1
630	LU4563011	350	870	57,2	945	186,00	1