

Information sheet

Replacement “Rubber, buttoned” (manhole cover)

Spare parts:

4x cushioning insert “Budatop”



Note: A manhole cover with a “Step” opening requires the cushioning insert to be cut to size.

1x contact adhesive (e.g. “Pattex”)



Required tools:

Small hammer

Spatula

Screwdriver

Brush for cleaning

Scissors or carpet cutter

Steps

A) Remove the old cushioning insert (lever out with screwdriver)

B) If necessary, remove adhesive residue with the spatula and clean the area with the brush

C) Apply contact adhesive (e.g. Pattex, etc.) to the surface.

C) Position the new cushioning insert so that the holes are placed on the cast iron buttons and use the hammer to fasten it in place

1) Remove the rubber and the adhesive residue

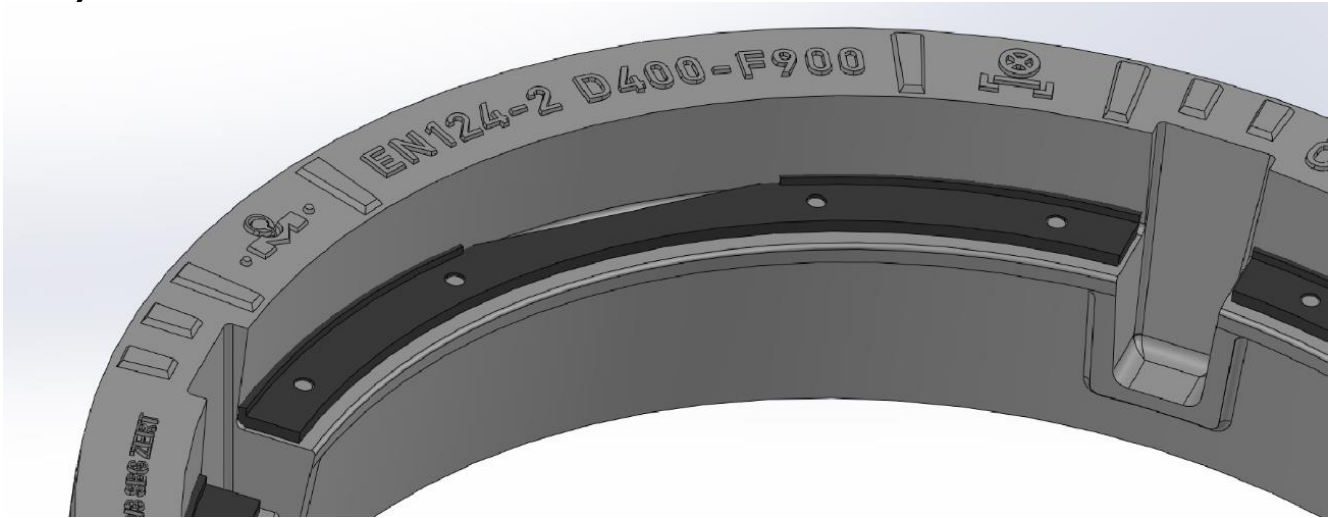

2) Apply contact adhesive

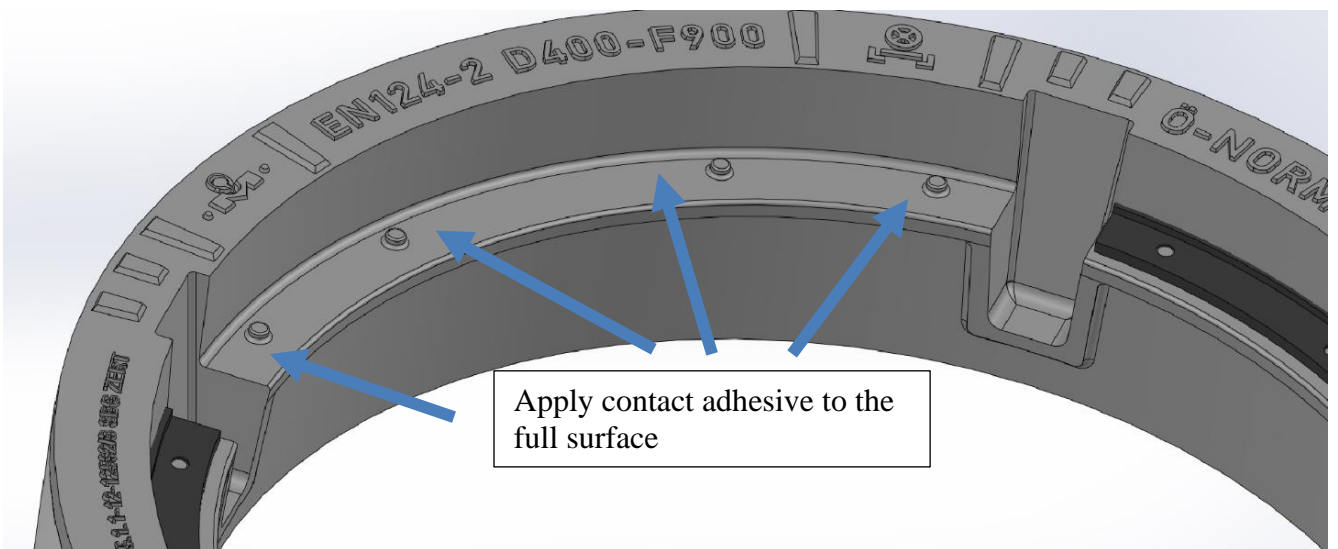

3) “Step” opening area: Remove rubber

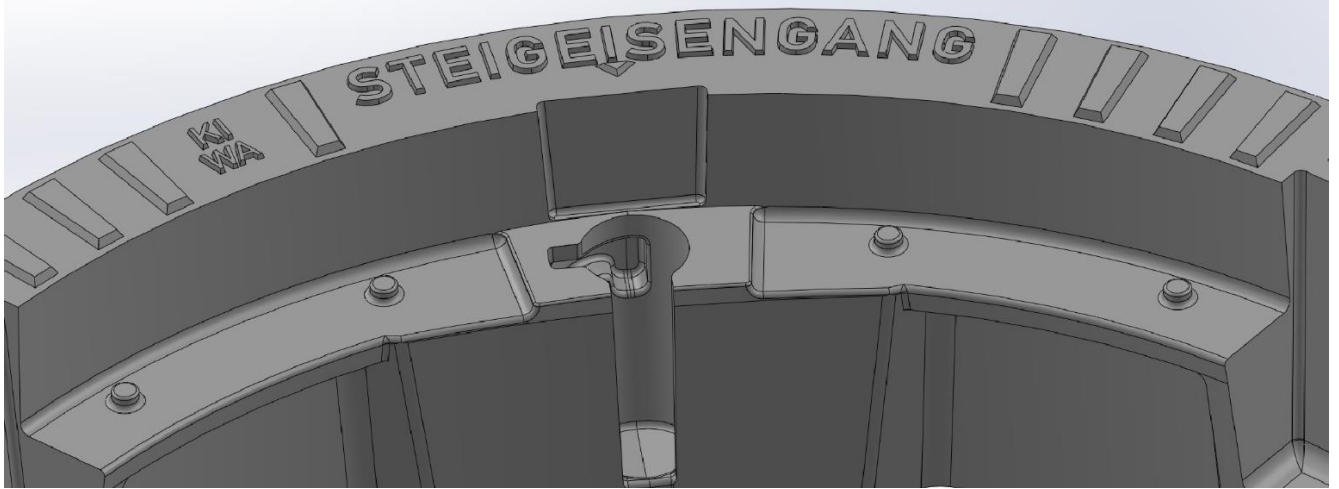

4) Cut rubber to size and glue in place

