



SEAMLESS BEND 11°

SDR 11



water
16 bar



gas
10 bar



hydrogen
10 bar



PE 100-RC
material



MRS 10 MPa



butt
welding



electrofusion
welding

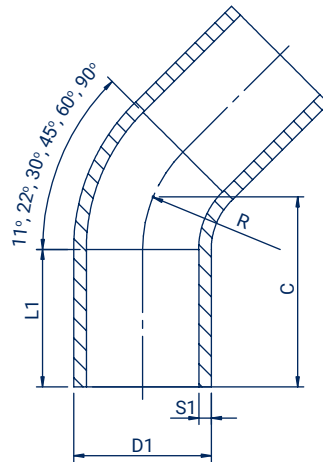

Size D1 (mm)	Code	L1 (mm)	C (mm)	S1 (mm)	R (mm)	Weight (kg)	Packing
32	LU1103211	70	98	2,9	48	0,08	1
40	LU1104011	75	106	3,7	60	0,12	1
50	LU1105011	80	130	4,6	75	0,22	1
63	LU1106311	90	150	5,8	94,5	0,35	1
75	LU1107511	100	155	6,8	112,5	0,52	1
90	LU1109011	150	350	8,2	135	1,42	1
110	LU1111011	150	330	10	165	2,14	1
125	LU1112511	150	380	11,4	188	3,38	1
140	LU1114011	150	395	12,7	210	3,96	1
160	LU1116011	150	415	14,6	480	5,54	1
180	LU1118011	150	450	16,4	270	7,49	1
200	LU1120011	150	480	18,2	300	9,88	1
225	LU1122511	150	510	20,5	338	13,36	1
250	LU1125011	250	540	22,7	375	17,66	1
280	LU1128011	250	400	25,4	420	16,30	1
315	LU1131511	250	460	28,6	472,5	21,85	1
355	LU1135511	300	540	32,2	532,5	41,00	1
400	LU1140011	300	560	36,3	600	45,90	1
450	LU1145011	300	580	40,9	675	60,20	1
500	LU1150011	350	650	45,4	750	83,30	1
560	LU1156011	350	680	50,8	840	108,60	1
630	LU1163011	350	730	57,2	945	148,30	1