



# ELECTROFUSION ELBOW 45° WITH BRASS TRANSITION SDR 11



water  
16 bar



gas  
10 bar



hydrogen  
10 bar



PE 100-RC  
material



MRS 10 MPa



threads according  
to EN10266-1

MALE THREAD I

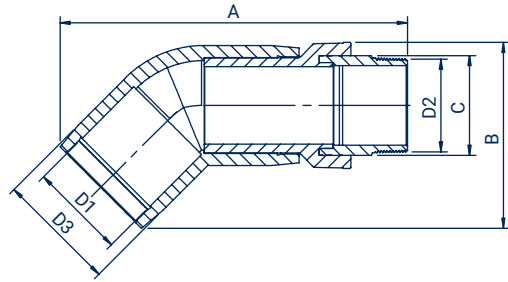

Size D1/D2 (mm)	Code	C (mm)	D3 (mm)	A (mm)	B (mm)	Weight (kg)	Packing
20 x 1/2"	KGZ45020012	22	35	147	67	0,15	36
25 x 3/4"	KGZ45025034	28	37	150	71	0,14	30
32 x 1"	KGZ45032001	34	44	163	78	0,25	20
40 x 1"	KGZ45040001	34	56	177	86	0,33	12
40 x 1 1/4"	KGZ45040114	44	56	184	88	0,42	12
50 x 1 1/2"	KGZ45050112	49	67	201	97	0,54	10
63 x 2"	KGZ45063002	61	81	231	115	0,94	10
75 x 2 1/2"	KGZ45075212	76	93	272	142	1,37	8
90 x 3"	KGZ45090003	88	112	306	165	2,03	6
110 x 4"	KGZ45110004	114	135	344	189	3,29	5
125 x 4"	KGZ45125004	114	151	263	210	3,64	4

FEMALE THREAD I

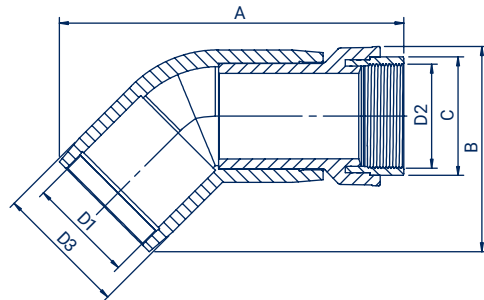

Size D1/D2 (mm)	Code	C (mm)	D3 (mm)	A (mm)	B (mm)	Weight (kg)	Packing
20 x 1/2"	KGW45020012	26	35	133	67	0,14	35
25 x 3/4"	KGW45025034	32	37	135	71	0,15	40
32 x 1"	KGW45032001	40	44	145	78	0,22	25
40 x 1"	KGW45040001	40	56	159	86	0,29	14
40 x 1 1/4"	KGW45040114	48	56	167	89	0,34	14
50 x 1 1/2"	KGW45050112	55	67	181	98	0,46	10
63 x 2"	KGW45063002	67	81	207	116	0,68	15
75 x 2 1/2"	KGW45075212	83	93	245	145	1,06	8
90 x 3"	KGW45090003	96	112	278	165	1,65	8
110 x 4"	KGW45110004	122	135	308	189	2,44	5
125 x 4"	KGW45125004	122	151	327	210	2,79	4