



# ELECTROFUSION ELBOW BHZ 90°

SDR 11



water  
16 bar



gas  
10 bar



hydrogen  
10 bar



PE 100-RC  
material



MRS 10 MPa



ready  
to use



bilateral heating  
zones

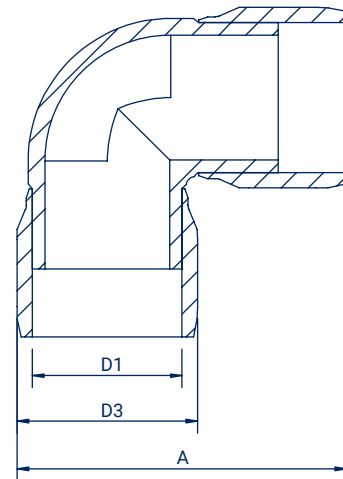

Size D1 (mm)	Code	A (mm)	D3 (mm)	Weight (kg)	Packing
140	KED9014011	372	168	2,01	6
180	KED9018011	412	213	7,00	1
200	KED9020011	448	238	9,20	1
225	KED9022511	496	266	12,71	2
250	KED9025011	540	299	17,80	1
280	KED9028011	570	336	26,40	1
315	KED9031511	645	379	35,00	1
355	KED9035511	893	425	69,80	1
400	KED9040011	1 370	476	95,50	1
450	KED9045011	1 074	537	139,00	1
500	KED9050011	1 199	600	145,00	1