

DN600-500x300.SM.PIPE

RASĒJUMA Nr.: LV.DN600-500x300.CELA.GULIJA	VERSIJA LV	REDAKCIJA 1	REDAKCIJAS STATUSS AKTUĀLS
---	---------------	----------------	-------------------------------

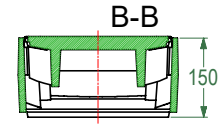
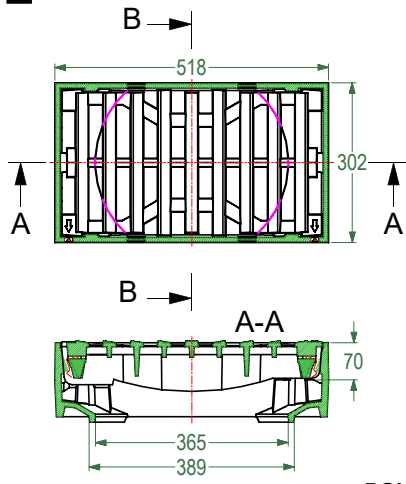
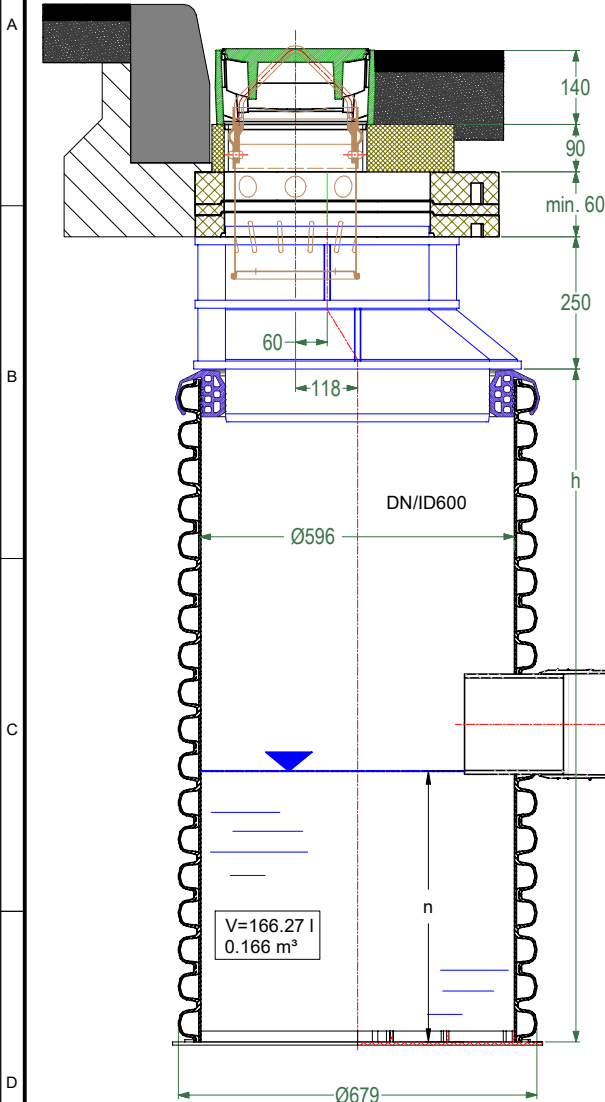

Kantaina četa lūkas pārsedze ar resti 500x300 (atvērums Ø350), h=140 mm
 Svars: 43 kg
 EN 124-2, D400 kN klase, RAL-GZ 692, DIN 1229
 Restes spraugas platums: 26 mm
 leplūdes šķērsriezuma laukums: 586 cm²
 leplūdes restes laukuma ūdens caurlaides spēja pie nokrišņu slāņa biezuma:
 h = 10 mm : 15,6 l/s
 h = 50 mm : 34,9 l/s

POLIMĒRA ATBALSTA GREDZENS TX/650/395/P (DIN 4052-10b)

GRUŽU UZTVĒRĒJSPAINIS ANALOGS DIN 4052-D1 - izbūvējams pēc vajadzības

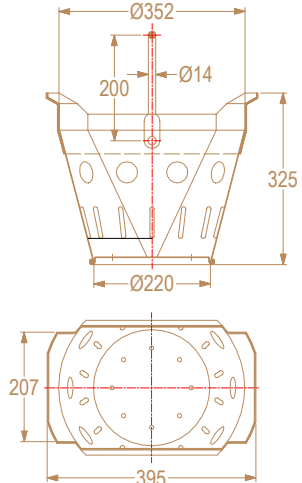

Materiāls: Cinkotais tērauds
 Svars: 3 kg
 Forma: D - īsā
 Paredzēta lūkas pārsedzēm: 500x300 mm

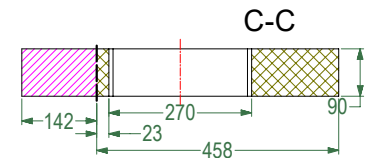
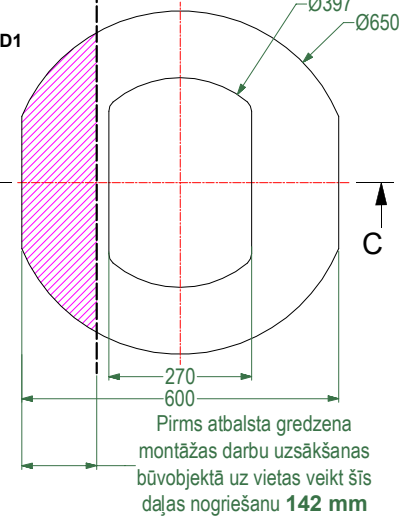

Polimēra paaugstinošie gredzeni (izbūvējami pēc vajadzības)

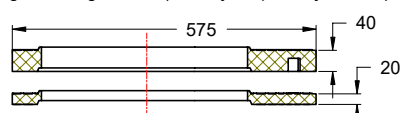

Polimēra atbalsta gredzens

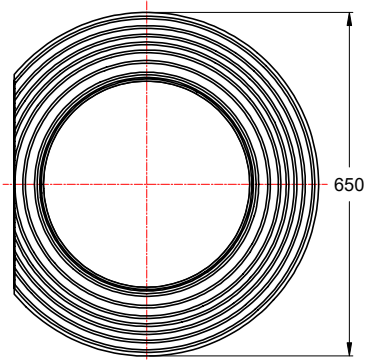
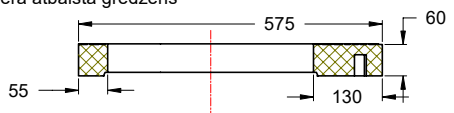

DIN 4052-10a

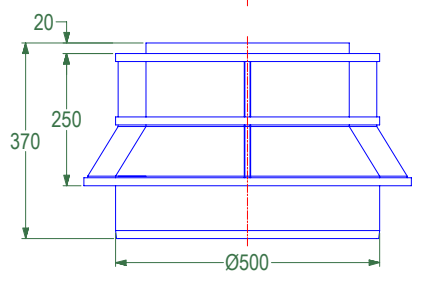
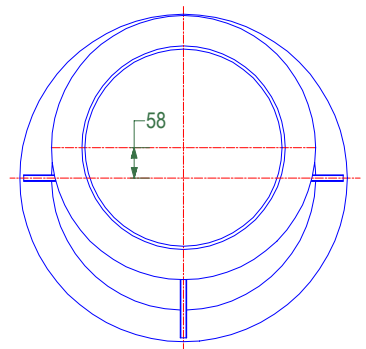
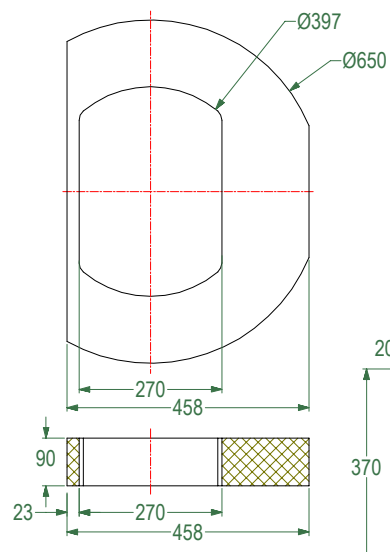

SIA "EVOPIPES"
 Langervaldes iela 2a, Jelgava, LV-3002, Latvija
 Vienotais reģ. Nr.: 50003728871
 Tālrunis: +371 63094300
 e-pasts: info@evopipes.lv
 Mājas lapa: www.evopipes.lv

FAILA NOSAUKUMS:
 LV.DN600-500x300.Cela.gulija.dwg

LAPA: 1 NO 1

LAPAS FORMĀTS: @ A4

MĒROGS:
 BEZ MĒROGA

STADIJA:
 TIPVEIDA RASĒJUMS