



SPIGOT ELBOW 45°

SDR 11



water
16 bar



gas
10 bar



hydrogen
10 bar



PE 100-RC
material



MRS 10 MPa



butt
welding



electrofusion
welding

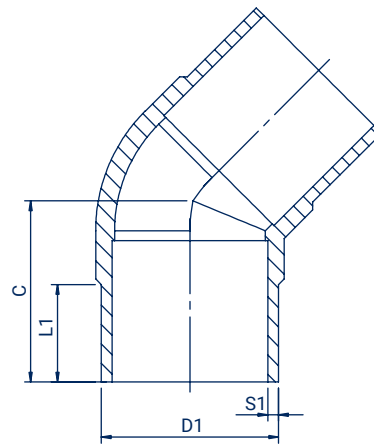

Size D1 (mm)	Code	L1 (mm)	C (mm)	S1 (mm)	Weight (kg)	Packing
25	KD4502511	48	42	3	0,02	-
32	KD4503211	57	49	3	0,04	15
40	KD4504011	63	53	3,7	0,06	10
50	KD4505011	66,5	57	4,6	0,10	10
63	KD4506311	66	88	5,8	0,21	30
75	KD4507511	71	90	6,8	0,29	25
90	KD4509011	83	109	8,2	0,45	16
110	KD4511011	109	139	10	0,94	8
125	KD4512511	93	124	11,4	0,95	8
140	KD4514011	121	168	12,7	1,76	8
160	KD4516011	120	161	14,6	2,21	6
180	KD4518011	108	153	16,4	2,73	3
200	KD4520011	115	165	18,2	3,66	2
225	KD4522511	125	180	20,5	4,79	2
250	KD4525011	135	196	22,7	6,85	2
280	KD4528011	144	214	25,4	9,24	2
315	KD4531511	155	231	28,6	13,00	1