



SPIGOT TEE

SDR 17



water
10 bar



gas
5 bar



hydrogen
5 bar



PE 100-RC
material



10 MPa



butt
welding



electrofusion
welding

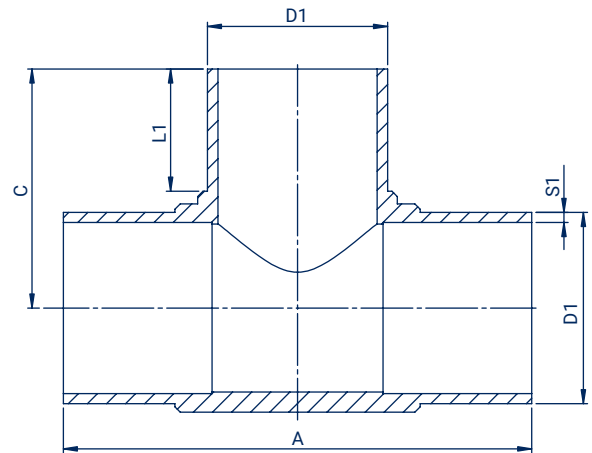

Size D1 (mm)	Code	A (mm)	L1 (mm)	C (mm)	S1 (mm)	Weight (kg)	Packing
63	TD06317	222	63	113	3,8	0,26	10
75	TD07517	246	72	122	4,5	0,40	5
90	TD09017	285	81	142	5,4	0,60	10
110	TD11017	319	88	158	6,6	1,04	10
125	TD12517	331	90	165	7,4	1,32	6
140	TD14017	395	104	197	8,3	2,21	-
160	TD16017	396	104	200	9,5	2,54	4
180	TD18017	427	110	215	10,7	3,49	2
200	TD20017	466	118	240	11,9	4,59	2
225	TD22517	505	126,5	251	13,4	6,20	1
250	TD25017	557	136	279	14,8	8,37	1
280	TD28017	610	145	305	16,6	11,30	1
315	TD31517	665	155	330	18,7	15,50	1
355	TD35517	818	165	408	21,1	25,98	-
400	TD40017	910	197	455	23,7	36,06	-
450	TD45017	955	197	478	26,7	50,62	-
500	TD50017	1050	218	525	29,7	68,32	-