



VALVE WRENCH



water



gas







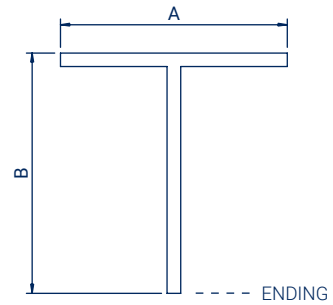

hydrogen



top
quality



Code	A (mm)	B (mm)	Ending	For product	Weight (kg)
KEYBV	400	65	 □50	BVS025-125 BVR160-200	0,80
KEYKZPM	585	835	 □30	KZP060100M1C KZP120200M1C	2,95
KEYKZPS	600	320	 □15	KZN060100S1F KZN120200S1F KZP060100S1B KZP120200S1B KZP060100S1A KZP120200S1A	0,50
KEYTS12	300	257	 ○12	TS	0,72
KEYTS17	300	257	 ○17	TS	0,95
KEYTSFL17	350	425	 ○17	TS	0,50
KEYZNF	500	255	 □14	ZNF	1,31