



# SEAMLESS BEND 60°

## SDR 17



water  
10 bar



gas  
5 bar



hydrogen  
5 bar



PE 100-RC  
material



MRS 10 MPa



butt  
welding



electrofusion  
welding

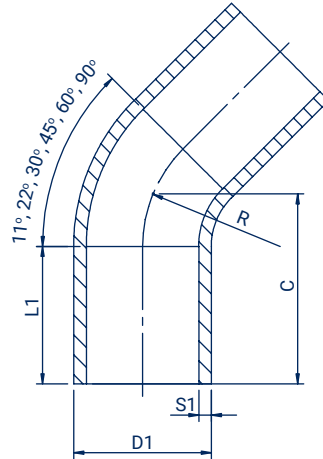

Size D1 (mm)	Code	L1 (mm)	C (mm)	S1 (mm)	R (mm)	Weight (kg)	Packing
63	LU6006317	90	173	3,8	94,5	0,27	1
75	LU6007517	100	182	4,5	112,5	0,42	1
90	LU6009017	260	350	5,4	135	0,88	1
110	LU6011017	120	270	6,6	165	1,37	1
125	LU6012517	150	283	7,4	187,5	1,67	1
140	LU6014017	150	296	8,3	210	2,20	1
160	LU6016017	150	313	9,5	240	3,20	1
180	LU6018017	300	460	10,7	270	5,77	1
200	LU6020017	320	490	11,9	300	7,10	1
225	LU6022517	330	530	13,4	338	9,39	1
250	LU6025017	250	500	14,8	375	9,50	1
280	LU6028017	250	530	16,6	420	15,78	1
315	LU6031517	250	612	18,7	472,5	19,50	1
355	LU6035517	300	690	21,1	532,5	30,10	1
400	LU6040017	300	730	23,7	600	38,20	1
450	LU6045017	300	780	26,7	675	53,70	1
500	LU6050017	350	880	29,7	750	73,90	1
560	LU6056017	350	930	33,2	840	98,20	1
630	LU6063017	350	1000	37,4	945	132,30	1