



SPIGOT TEE

SDR 11



water
16 bar



gas
10 bar



hydrogen
10 bar



PE 100-RC
material



MRS 10 MPa



butt
welding



electrofusion
welding

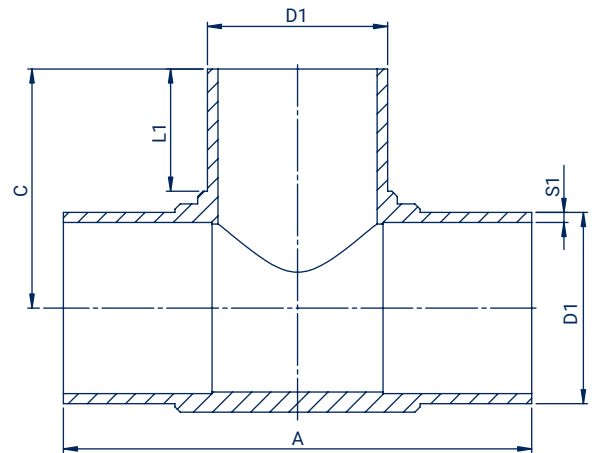

Size D1 (mm)	Code	A (mm)	L1 (mm)	C (mm)	S1 (mm)	Weight (kg)	Packing
25	TD02511	117	39	59	3	0,04	-
32	TD03211	139	46	67	3	0,06	10
40	TD04011	165	50	84	3,7	0,11	10
50	TD05011	189	56	95	4,6	0,18	6
63	TD06311	216	65	105	5,8	0,34	16
75	TD07511	248	72	122	6,8	0,54	5
90	TD09011	292	84	146	5,4	0,87	10
110	TD11011	315	87	157	10	1,35	8
125	TD12511	332	90	165	11,4	1,95	6
140	TD14011	399	104	200	12,7	3,21	-
160	TD16011	396	106	200	14,6	3,50	2
180	TD18011	430	110	219	16,4	4,90	2
200	TD20011	471	121	235	18,2	6,55	2
225	TD22511	507	127	261	20,5	8,95	1
250	TD25011	556	135	281	22,7	12,32	1
280	TD28011	610	146	350	25,4	16,36	1
315	TD31511	665	155	330	28,6	22,24	1
355	TD35511	829	167	414	32,2	38,02	-
400	TD40011	913	198	457	36,3	52,01	-
450	TD45011	954	198	477	40,9	74,60	-
500	TD50011	1050	218	525	45,4	100,00	-