

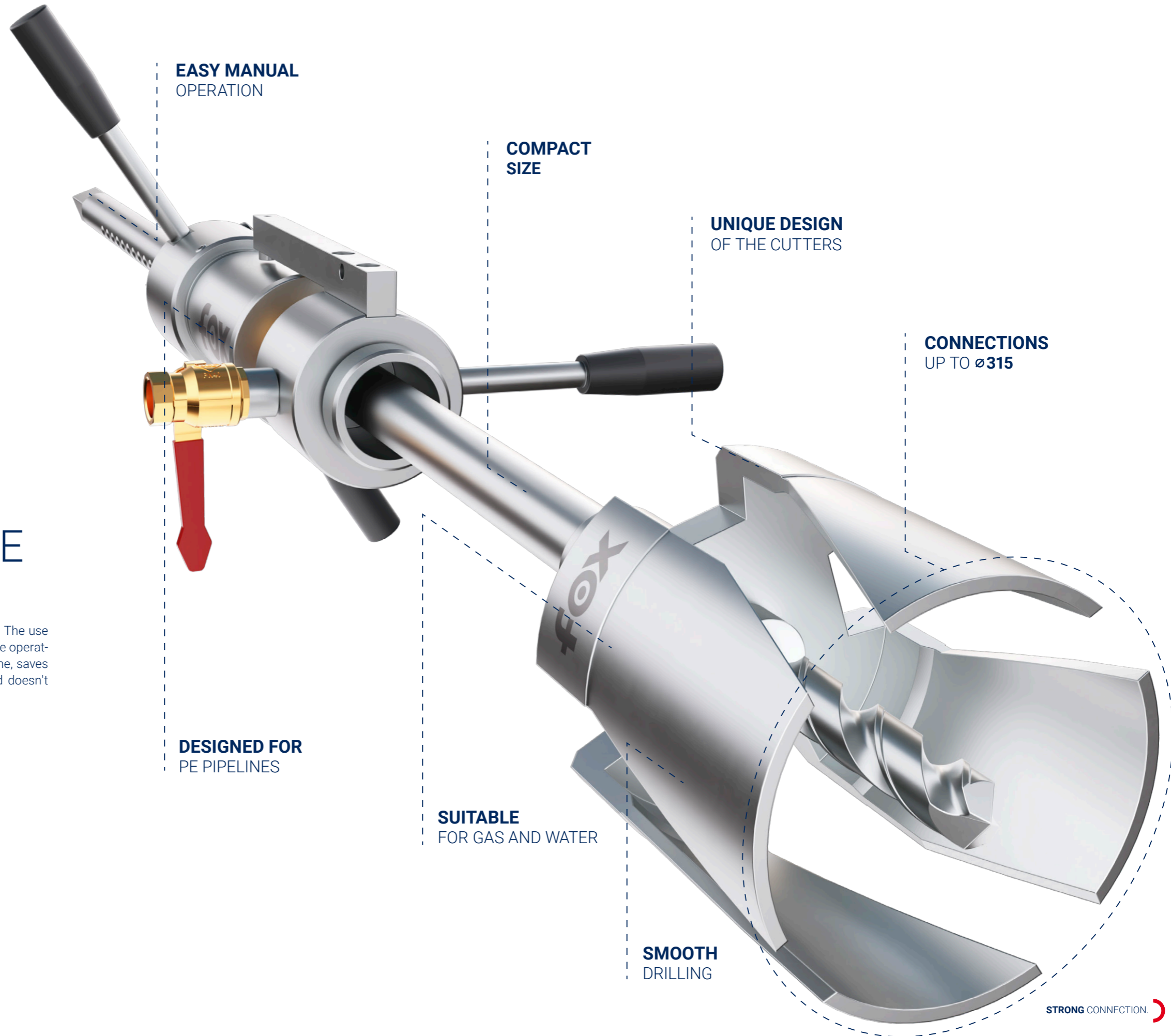

FOXDLT

EQUIPMENT FOR DRILLING UNDER PRESSURE

FOXDLT is the most efficient solution available on the market. The use of our device significantly reduces the time of connecting to the operating network, minimizes the risk of contamination of the pipeline, saves costs connected with closing and restarting the pipeline and doesn't cause water loss.



Parameters	Unit	Data	
Available cutters	DN (mm)	63 (ø49), 90 (ø71), 110 (ø87), 160 (ø127), 180 (ø140), 225 (ø180), 315 (ø250)	
Max. operating pressure	bar	16	
Pipeline diameter	mm	SDR 11	63 - 800
		SDR 17	63 - 1200
Max. turning speed of the pivot	turns/min	30	
Max. working length	m	0,8	
Total weight	kg	27,1	
Weight of the cutters (set)	kg	19	

