



SEAMLESS BEND 22°

SDR 11



water
16 bar



gas
10 bar



hydrogen
10 bar



PE 100-RC
material



MRS 10 MPa



butt
welding



electrofusion
welding

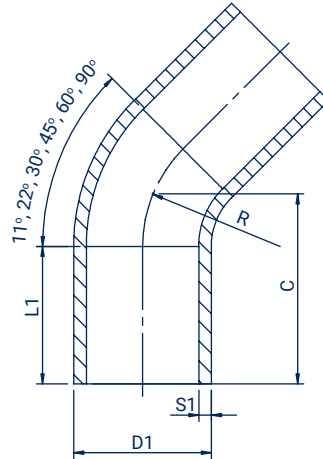

Size D1 (mm)	Code	L1 (mm)	C (mm)	S1 (mm)	R (mm)	Weight (kg)	Packing
32	LU2203211	70	98	2,9	48	0,08	1
40	LU2204011	75	106	3,7	60	0,10	1
50	LU2205011	80	130	4,6	75	0,20	1
63	LU2206311	90	150	5,8	94,5	0,35	1
75	LU2207511	100	155	6,8	112,5	0,58	1
90	LU2209011	150	350	8,2	135	1,42	1
110	LU2211011	150	330	10	165	2,07	1
125	LU2212511	150	380	11,4	188	3,06	1
140	LU2214011	150	395	12,7	210	3,96	1
160	LU2216011	150	420	14,6	480	5,66	1
180	LU2218011	150	450	16,4	270	7,49	1
200	LU2220011	150	480	18,2	300	9,88	1
225	LU2222511	150	510	20,5	338	13,36	1
250	LU2225011	250	550	22,7	375	17,66	1
280	LU2228011	250	400	25,4	420	16,30	1
315	LU2231511	250	460	28,6	472,5	21,85	1
355	LU2235511	300	540	32,2	532,5	37,00	1
400	LU2240011	300	560	36,3	600	45,90	1
450	LU2245011	300	580	40,9	675	60,20	1
500	LU2250011	350	650	45,4	750	83,30	1
560	LU2256011	350	680	50,8	840	108,60	1
630	LU2263011	350	730	57,2	945	171,00	1