

NO.	Part name	Comment	Qty.
1	Cover	PP/PE/cast iron	1
2	Maintenance shaft	PP/PE	1
3	Double-wall tank, DN/ID1200, SN4	PE	1
4	Connection DN/OD110 or DN/OD160	PE	2
5	End cap, ID1200	PE	2
6	Mounting hook	Sheet 25mm	4

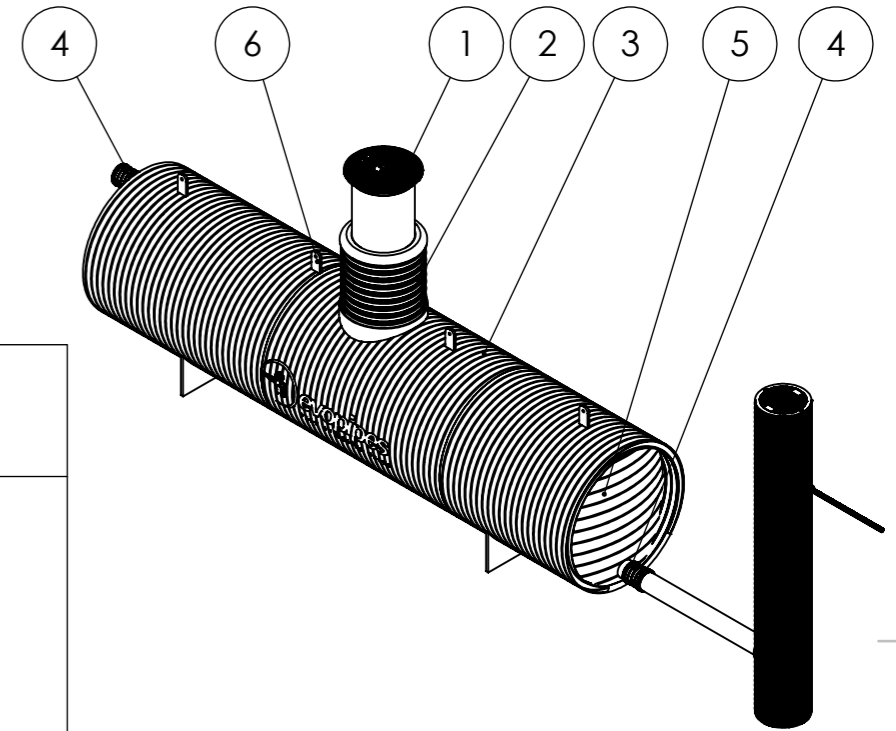

Maintenance shaft version

V1	V2	V3	V4	V5	V6
DN400, A15	DN400/315, D400	DN/ID600	ID600/500, D400	ID600 B125	ID600, D400
A15 Ø 400	D400 Ø 315 Ø 400	Max 200kg Ø 678,9	D400 Ø 500 Ø 678,9	B125 Ø 678,9	D400 Ø 678,9

Total volume of the tank, V (m3)	**Length, L (m)
6	5,5
8	7,2
10	9
12	10,8
15	13,4

Total volume of the tank	V=	m3
ID400 pump station	Y <input type="checkbox"/>	N <input type="checkbox"/>
Connecting diameter, DN1	DN/OD110 <input type="checkbox"/>	DN/OD160 <input type="checkbox"/>
Height from ground to DN1 flow channel	H1=	mm / standard 950mm <input type="checkbox"/>
Connecting diameter, DN2	DN/OD110 <input type="checkbox"/>	DN/OD160 <input type="checkbox"/>
Height from ground to DN2 flow channel	H2=	mm
Maintenance shaft version	V1 <input type="checkbox"/>	V2 <input type="checkbox"/> V3 <input type="checkbox"/> V4 <input type="checkbox"/> V5 <input type="checkbox"/> V6 <input type="checkbox"/>
Maintenance shaft location	L1=	mm / middle <input type="checkbox"/>
Tank liquid level control device	Y <input type="checkbox"/>	N <input type="checkbox"/>

****The indicated length is approximate and deviations are possible within the norm during production.**

***Other volume, length, connection solutions upon requests.**

DRAWN MAMS	SIGNATURE	DATE	FORMAT A3	SCALE 1:20	 Langervaldes sreet 2a, Jelgava, LV-3002, Latvia, Reg. No: 50003728871 Phone: +371 63094300 E-mail: info@evopipes.lv Web: www.evopipes.lv
APPVD			ORDER No.	SHEET 1 / 1	
Type	Order form			REVISION 0	CUSTOMER Tank DN1200
Unless otherwise specified: dimensions are in millimeters tolerances according to DIN 16901 do not scale drawing		MATERIAL	VOLUME	WEIGHT	This drawing is the property of SIA Evopipes and is protected by law.