

DRAWING No.:	VERSION	REVISION	REVISION STATUS
BORTA RESTE D400	EN	1	ACTUAL

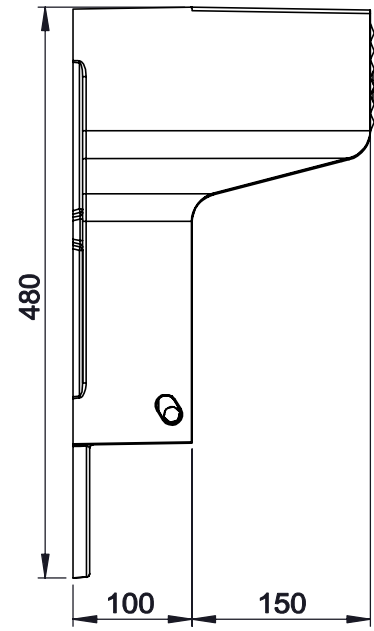
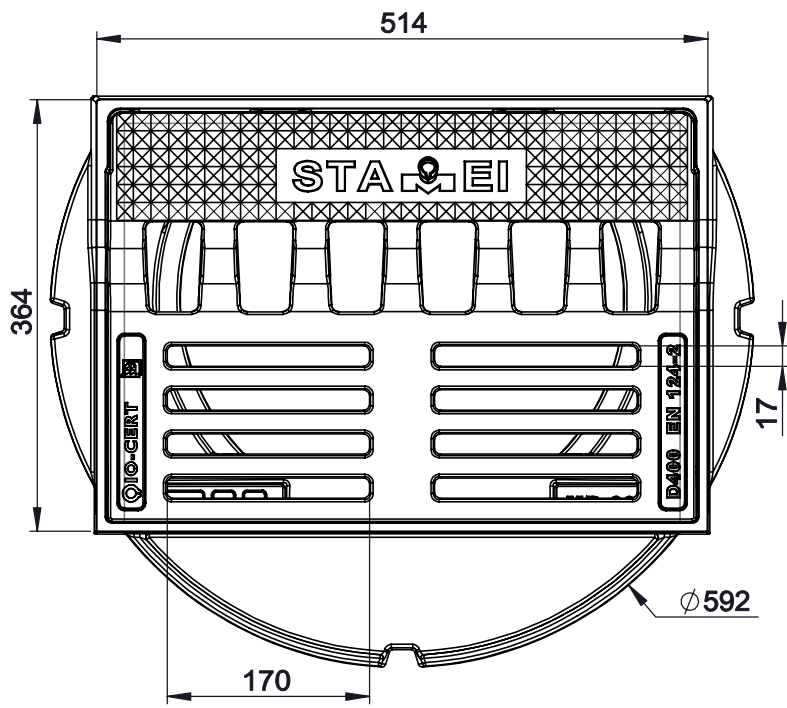
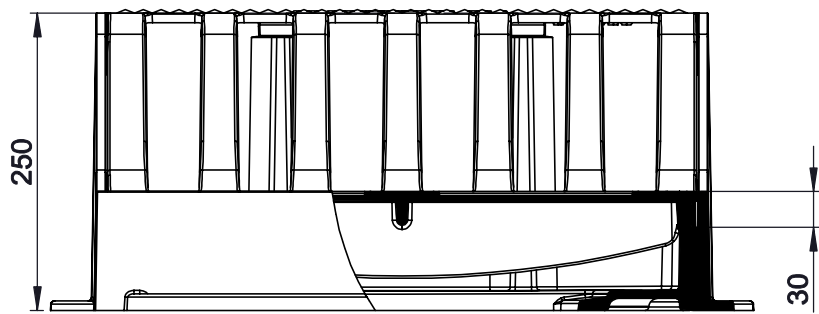

Stationary type onboard grate D400

Conformity: EN124-2
 Construction class: D400
 Material: cast iron
 Weight: 57.5 kg
 Distance between horizontal grating: 17 mm

MEIER  GUSS



SIA "EVOPIPES"
 Langervaldes str. 2a, Jelgava, LV-3002, Latvia
 Company reg. No.: 50003728871
 Phone: +371 63094300
 E-mail: info@evopipes.lv
 Website: www.evopipes.lv

FILE NAME:
 Borta reste D400.dwg

SHEET: 1 OF 1

SCALE:
 WITHOUT SCALE

SHEET FORMAT: @ A4

STAGE:
 STANDARD DRAWING

RASĒJUMA Nr.:	VERSIJA	REDAKCIJA	REDAKCIJAS STATUSS
BORTA RESTE D400	LV	1	AKTUĀLS

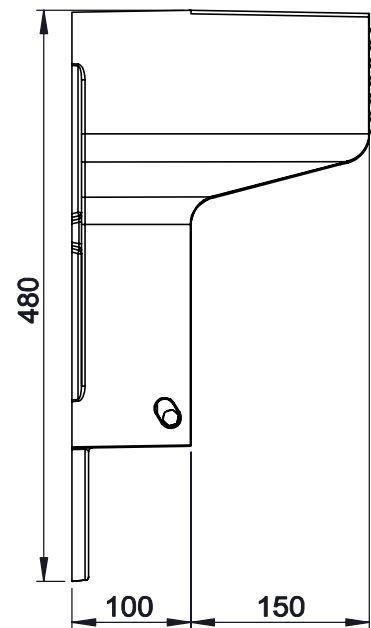
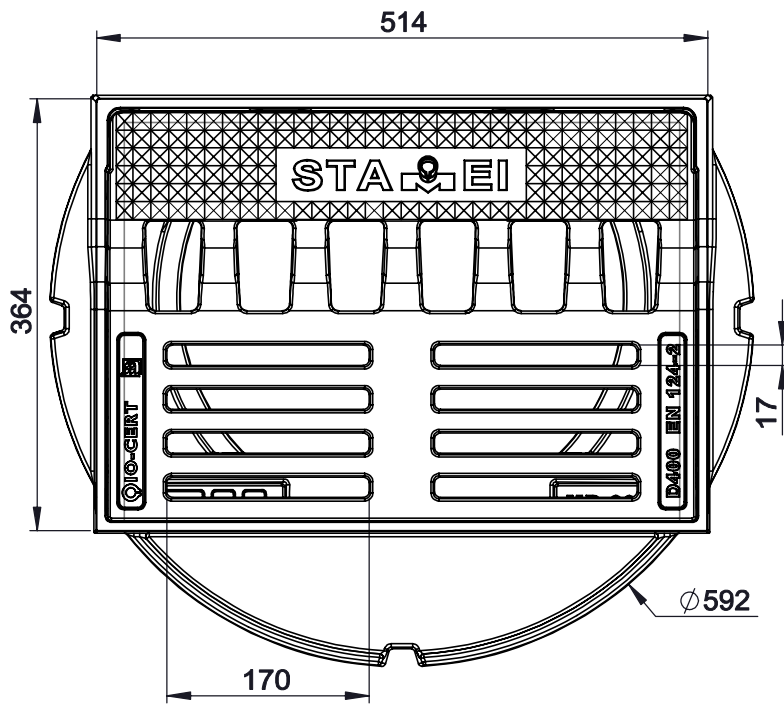
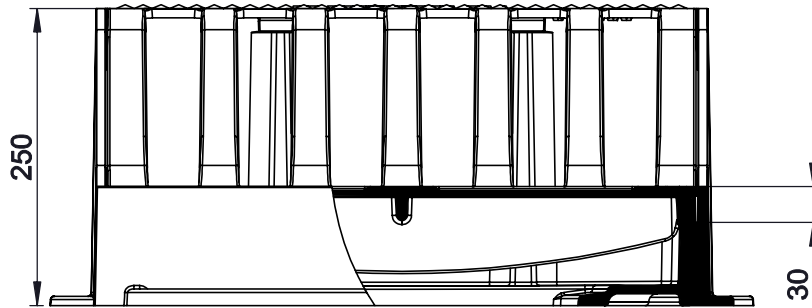

Stacionāra tipa borta reste D400

Atbilstība: LVS EN124-2

Izbūves klase: D400

Materiāls: kaļamais ķets (čuguns)

Svars: 57.5 kg

Attālums starp horizontālajām restēm: 17 mm

MEIER  **GUSS**



SIA "EVOPIPES"
 Langervaldes iela 2a, Jelgava, LV-3002, Latvija
 Vienotais reģ. Nr.: 50003728871
 Tālrunis: +371 63094300
 e-pasts: info@evopipes.lv
 Mājas lapa: www.evopipes.lv

FAILA NOSAUKUMS:

Borta reste D400.dwg

LAPA: 1 NO 1

LAPAS FORMĀTS: @ A4

MĒROGS:

BEZ MĒROGA

STADIJA:

TIPVEIDA RASĒJUMS