

DRAWING No.:	VERSION	REVISION	REVISION STATUS
CSL 600D Drainage chamber with cast iron cover	EN	1	ACTUAL

# CSL 600D (PR)

Lūkas pārsedes tipu (peldošs vai stacionārs) un slodzes klasi izvēlas atbilstoši projekta vajadzībām. Iespējamās lūkas pārsedes risinājumus skatīt [www.evopipes.lv](http://www.evopipes.lv), Produktu sadaļā - Vāki, restes un atbalsta gredzeni.

The chamber cover type (self-leveling or stationary) and load class must be selected according to the needs of the project. See [www.evopipes.com](http://www.evopipes.com) for possible chamber cover solutions in the Products section - Chamber covers, grates and support rings.

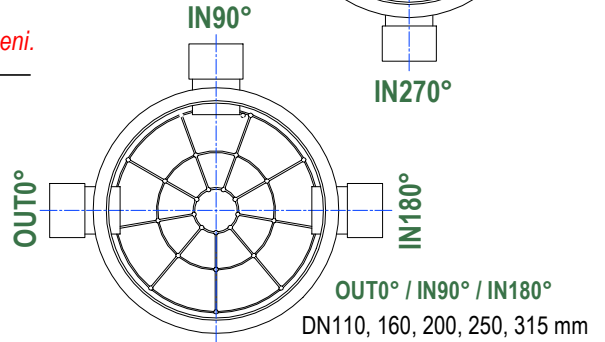
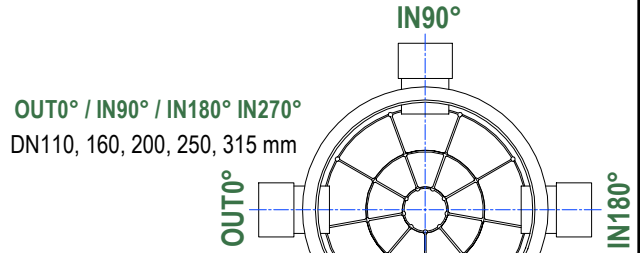

OUT0° / IN180° IN270°  
DN110, 160, 200, 250, 315 mm

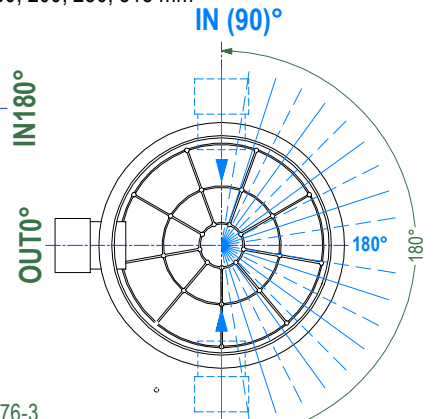
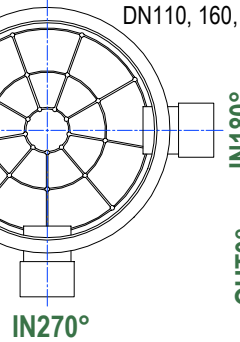
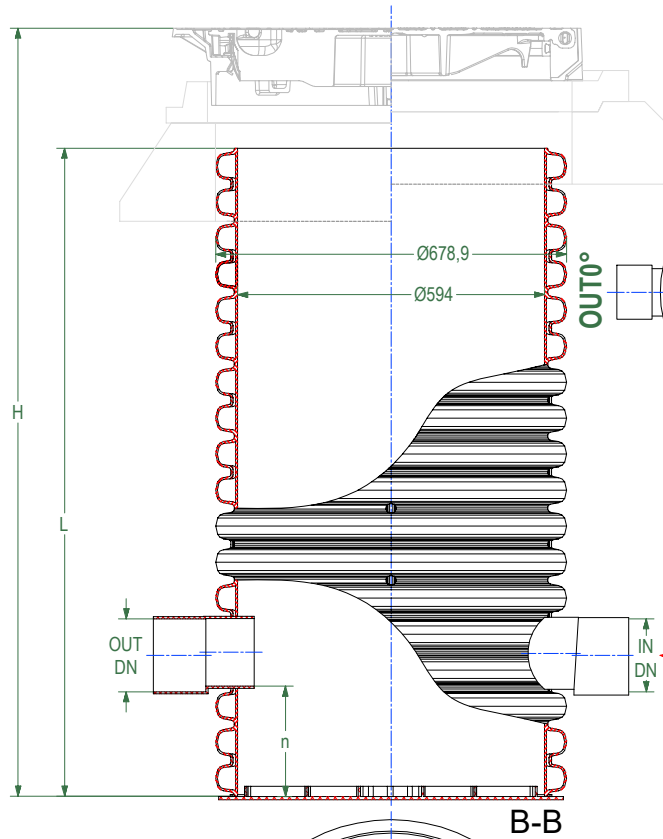

DN/OD, EN 13476-3

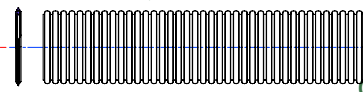

OUT0° / IN(90 - 270°)  
DN110, 160, 200, 250, 315 mm  
IN - requested connection in desirable angle

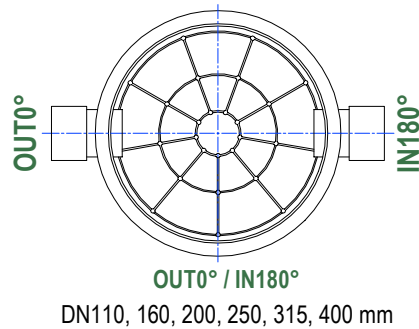
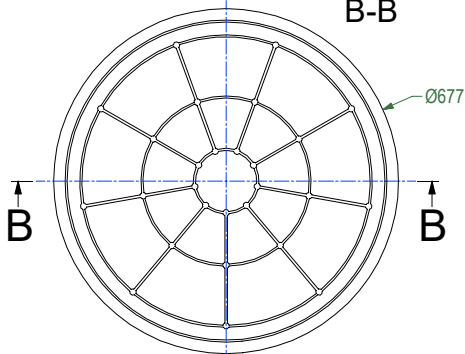

Šis rasējums ir SIA Evopipes intelektuālais īpašums. / This drawing is the property of SIA Evopipes and is protected by law.



SIA "EVOPIPES"  
Langervaldes str. 2a, Jelgava, LV-3002, Latvia  
Company reg. No.: 50003728871  
Phone: +371 63094300  
E-mail: [info@evopipes.lv](mailto:info@evopipes.lv)  
Website: [www.evopipes.lv](http://www.evopipes.lv)

FILE NAME:  
CSL 600D Drainage chamber with cast iron cover

SHEET: 1 OF 1

SHEET FORMAT: @ A4

SCALE:  
WITHOUT SCALE

STAGE:  
STANDARD DRAWING

DRAWING No.:	VERSION	REVISION	REVISION STATUS
CSL 600D Drainage chamber with cast iron cover	EN	1	ACTUAL

# CSL 600D (SM)

Lūkas pārsedes tipu (peldošs vai stacionārs) un slodzes klasi izvēlas atbilstoši projekta vajadzībām. Iespējamos lūkas pārsedes risinājumus skatīt [www.evopipes.lv](http://www.evopipes.lv), Produktu sadaļā - Vāki, restes un atbalsta gredzeni.

The chamber cover type (self-leveling or stationary) and load class must be selected according to the needs of the project. See [www.evopipes.com](http://www.evopipes.com) for possible chamber cover solutions in the Products section - Chamber covers, grates and support rings.

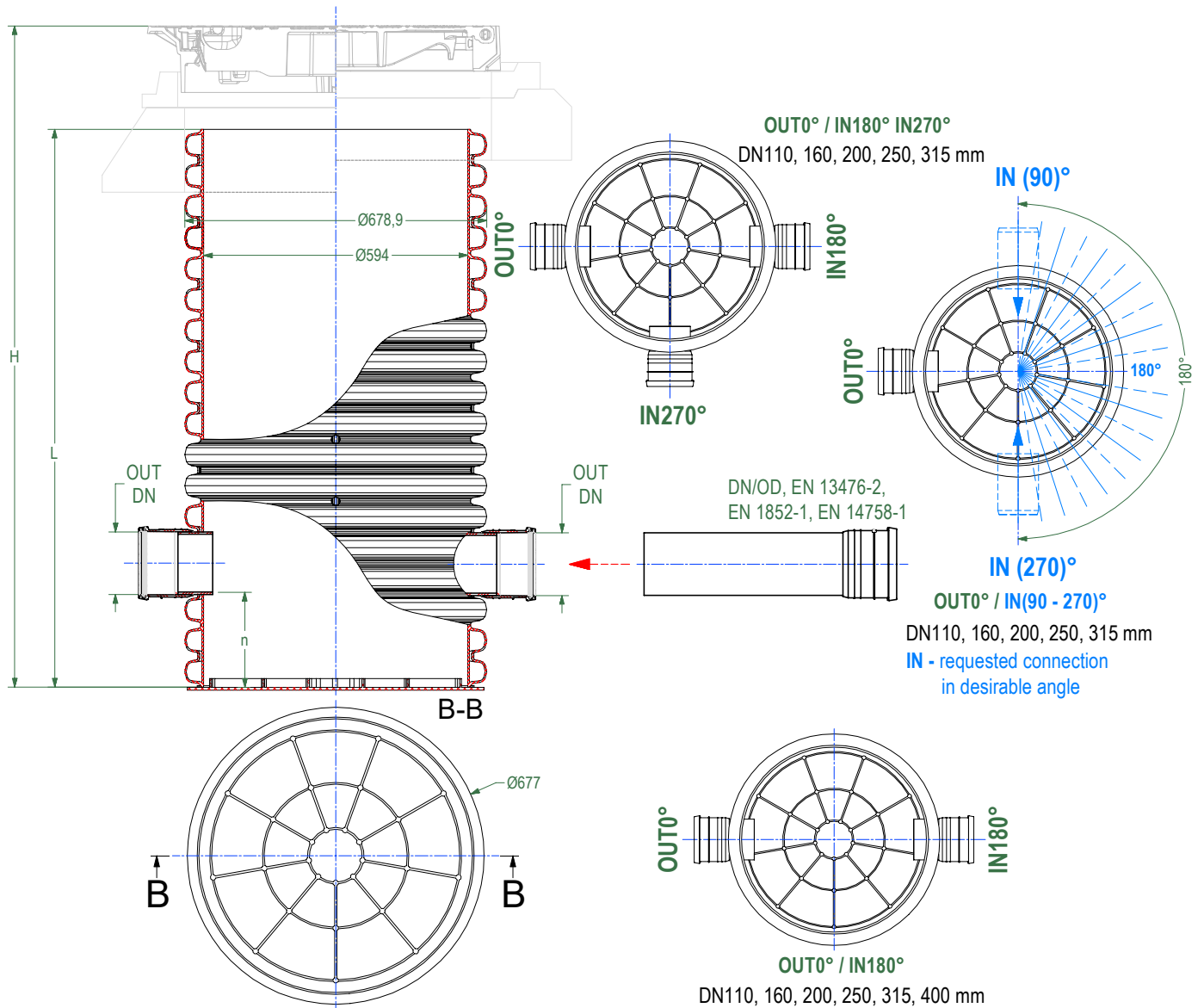
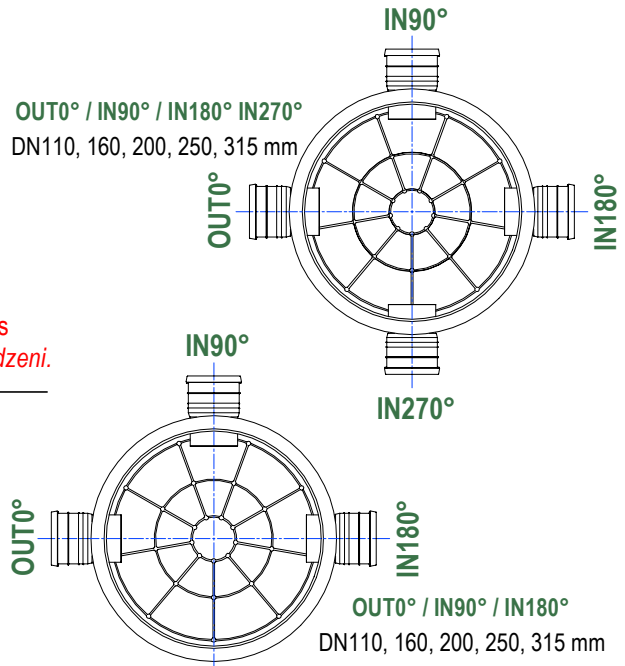

Šis rasējums ir SIA Evopipes intelektuālais īpašums. / This drawing is the property of SIA Evopipes and is protected by law.



SIA "EVOPIPES"  
Langervaldes str. 2a, Jelgava, LV-3002, Latvia  
Company reg. No.: 50003728871  
Phone: +371 63094300  
E-mail: [info@evopipes.lv](mailto:info@evopipes.lv)  
Website: [www.evopipes.lv](http://www.evopipes.lv)

FILE NAME:  
CSL 600D Drainage chamber with cast iron cover

SCALE:  
WITHOUT SCALE

SHEET: 1 OF 1

SHEET FORMAT: @ A4

STAGE:  
STANDARD DRAWING

DRAWING No.:	VERSION	REVISION	REVISION STATUS
CSL 600D Drainage chamber with cast iron cover	EN	1	ACTUAL

# CSL 600D (RB)

Lūkas pārsedes tipu (peldošs vai stacionārs) un slodzes klasi izvēlas atbilstoši projekta vajadzībām. Iespējamās lūkas pārsedes risinājumus skatīt [www.evopipes.lv](http://www.evopipes.lv), Produktu sadaļā - Vāki, restes un atbalsta gredzeni.

The chamber cover type (self-leveling or stationary) and load class must be selected according to the needs of the project. See [www.evopipes.com](http://www.evopipes.com) for possible chamber cover solutions in the Products section - Chamber covers, grates and support rings.

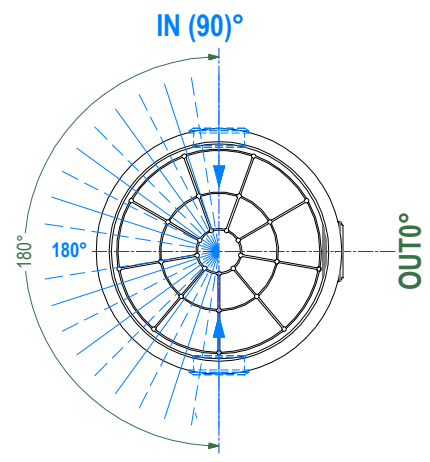

IN (90°)  
 IN (270°)  
 OUT0° / IN(90 - 270°)  
 DN110, 160, 200 mm  
 IN - requested connection in desirable angle

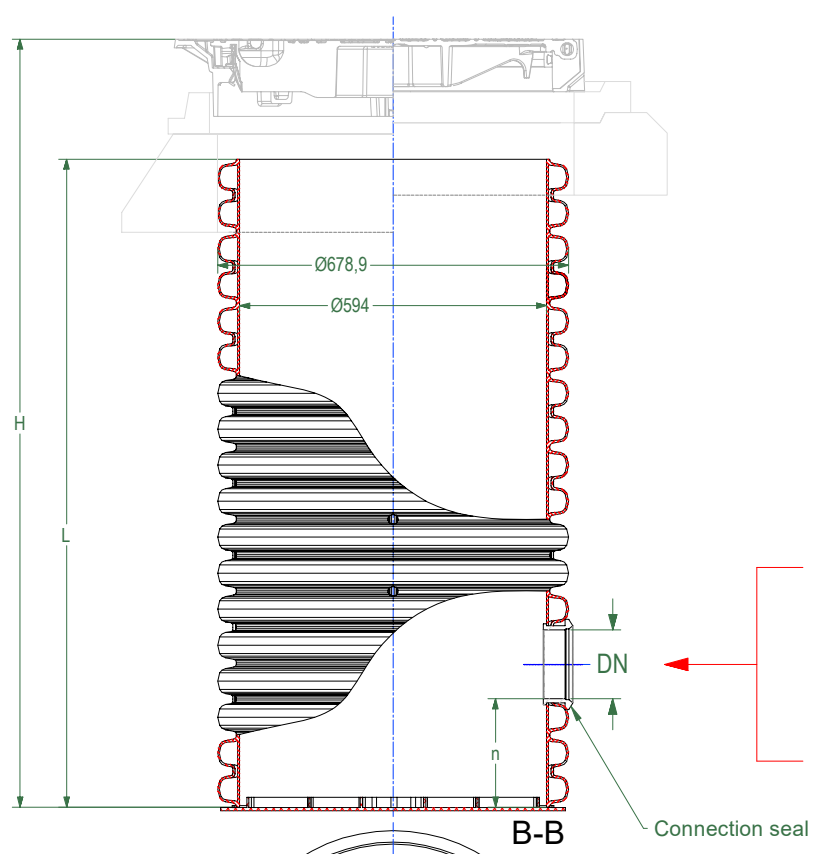

DN/OD, EN 13476-2,  
 EN 1852-1, EN 14758-1

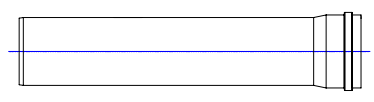

DN/OD, EN 13476-3

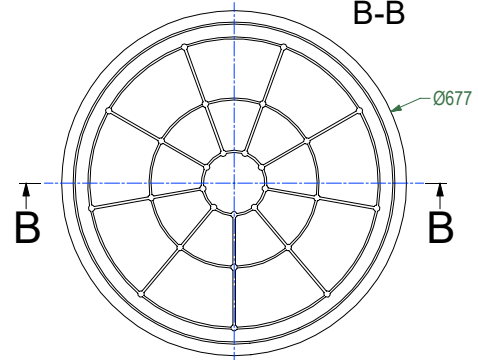
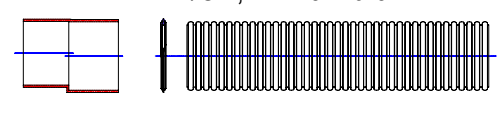

Šis rasējums ir SIA Evopipes intelektuālais īpašums. / This drawing is the property of SIA Evopipes and is protected by law.



SIA "EVOPIPES"  
 Langervaldes str. 2a, Jelgava, LV-3002, Latvia  
 Company reg. No.: 50003728871  
 Phone: +371 63094300  
 E-mail: [info@evopipes.lv](mailto:info@evopipes.lv)  
 Website: [www.evopipes.lv](http://www.evopipes.lv)

FILE NAME:  
 CSL 600D Drainage chamber with cast iron cover

SHEET: 1 OF 1

SHEET FORMAT: @ A4

SCALE:  
 WITHOUT SCALE

STAGE:  
 STANDARD DRAWING