



# SEAMLESS BEND 30°

## SDR 11



water  
16 bar



gas  
10 bar



hydrogen  
10 bar



PE 100-RC  
material



MRS 10 MPa



butt  
welding



electrofusion  
welding

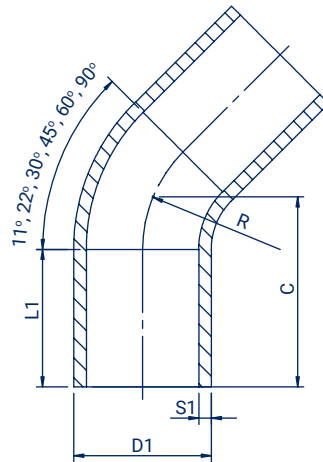

Size D1 (mm)	Code	L1 (mm)	C (mm)	S1 (mm)	R (mm)	Weight (kg)	Packing
32	LU3003211	70	98	2,9	48	0,08	1
40	LU3004011	75	106	3,7	60	0,12	1
50	LU3005011	80	130	4,6	75	0,22	1
63	LU3006311	90	150	5,8	94,5	0,35	1
75	LU3007511	100	155	6,8	112,5	0,47	1
90	LU3009011	150	350	8,2	135	1,42	1
110	LU3011011	150	330	10	165	2,07	1
125	LU3012511	150	380	11,4	188	3,06	1
140	LU3014011	150	400	12,7	210	3,96	1
160	LU3016011	150	420	14,6	480	5,54	1
180	LU3018011	150	450	16,4	270	7,49	1
200	LU3020011	150	480	18,2	300	9,88	1
225	LU3022511	150	520	20,5	338	13,36	1
250	LU3025011	250	560	22,7	375	17,66	1
280	LU3028011	250	400	25,4	420	18,28	1
315	LU3031511	250	460	28,6	472,5	26,00	1
355	LU3035511	300	540	32,2	532,5	31,70	1
400	LU3040011	300	560	36,3	600	50,20	1
450	LU3045011	300	580	40,9	675	62,00	1
500	LU3050011	350	650	45,4	750	91,00	1
560	LU3056011	350	680	50,8	840	116,00	1
630	LU3063011	350	730	57,2	945	173,00	1