

ID400 pump station

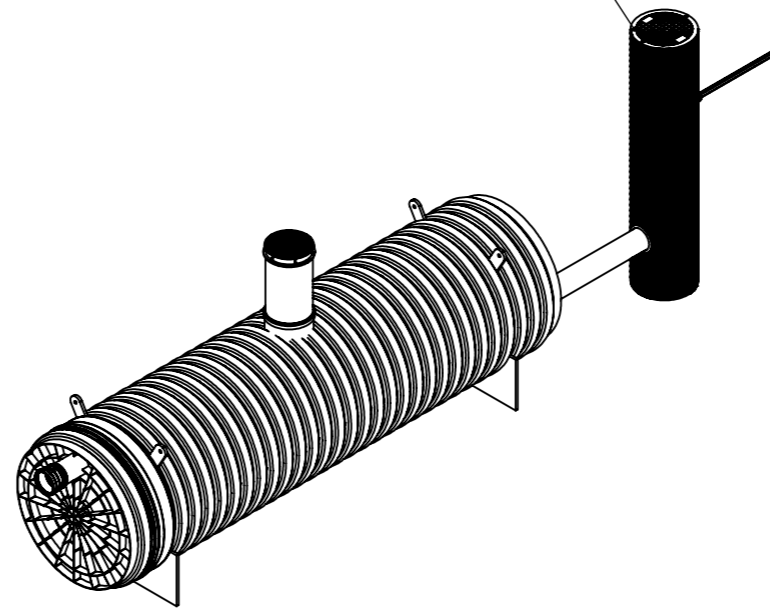

NO.	Part name	Comment	Qty.
1	Cover	PP/PE/cast iron	1
2	Maintenance shaft	PP/PE	1
3	Double-wall tank, DN/ID1000	PP	1
4	Connection, DN/OD110 or DN/OD160	PP	1
5	End cap, ID1000	PP	2
6	Mounting hook	Sheet 20mm	4

Maintenance shaft version

V1	V2	V3	V4	V5	V6
DN315, A15	DN400, A15	DN400/315, A15	DN400/315, D400	DN/ID600	DN/ID600/500, D400

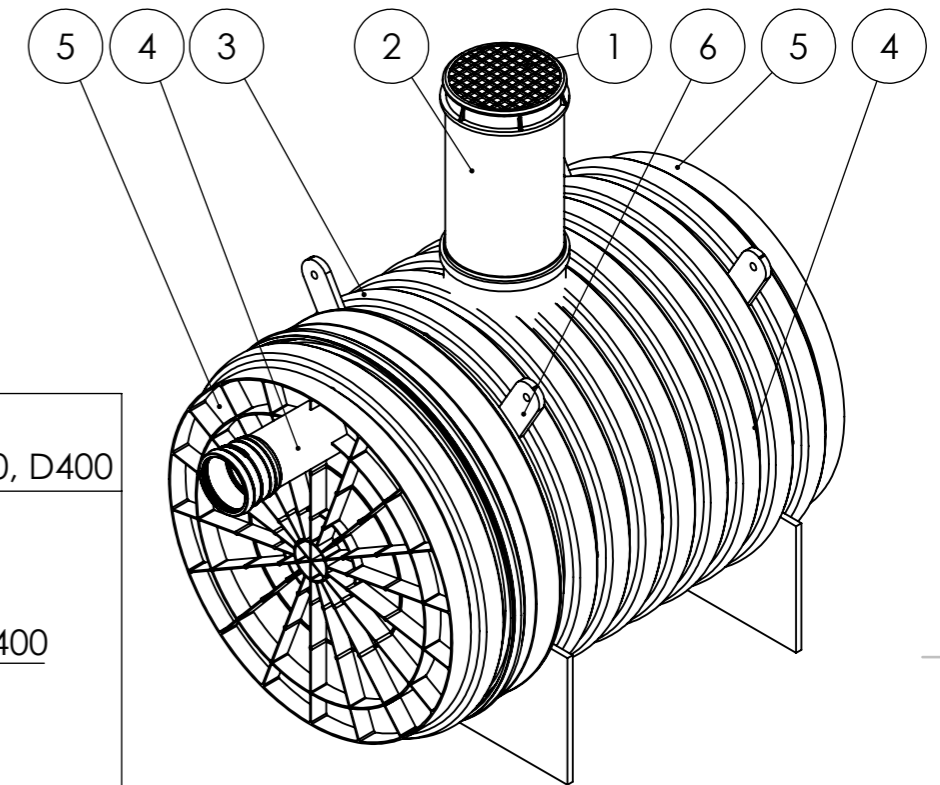

Total volume of the tank, V (m3)	**Length, L (m)
1	1,5
2	2,8
3	4,2
4	5,4
5	6,9
6	7,9
7	9,3
8	10,6
9	11,8
10	13,1

Total volume of the tank	V=	m3
ID400 pump station	Y <input type="checkbox"/>	N <input type="checkbox"/>
Connecting diameter, DN1	DN/OD110 <input type="checkbox"/>	DN/OD160 <input type="checkbox"/>
Height from ground to DN1 flow channel	H1=	mm / standard 950mm <input type="checkbox"/>
Connecting diameter, DN2	DN/OD110 <input type="checkbox"/>	DN/OD160 <input type="checkbox"/>
Height form ground to DN2 flow channel	H2=	mm
Maintenance shaft version	V1 <input type="checkbox"/>	V2 <input type="checkbox"/>
	V3 <input type="checkbox"/>	V4 <input type="checkbox"/>
	V5 <input type="checkbox"/>	V6 <input type="checkbox"/>
Maintenance shaft location	L1=	mm / middle <input type="checkbox"/>
Tank liquid level control device	Y <input type="checkbox"/>	N <input type="checkbox"/>

****Other volume, length, connection solutions upon requests.**
****The indicated length is approximate and deviations are possible within the norm during production.**

DRAWN MAMS	SIGNATURE	DATE	FORMAT A3	SCALE 1:20	 Langervaldes sreet 2a, Jelgava, LV-3002, Latvia, Reg. No: 50003728871 E-mail: info@evopipes.lv Web: www.evopipes.lv Phone: +371 63094300
APPVD			ORDER No.	SHEET 1 / 1	
Type	Order form			REVISION 0	CUSTOMER Tank DN1000
Unless otherwise specified: dimensions are in millimeters tolerances according to DIN 16901 do not scale drawing		MATERIAL	VOLUME	WEIGHT	This drawing is the property of SIA Evopipes and is protected by law.