



SPIGOT ELBOW 45°

SDR 17



water
10 bar



gas
5 bar



hydrogen
5 bar



PE 100-RC
material



10 MPa



butt
welding



electrofusion
welding

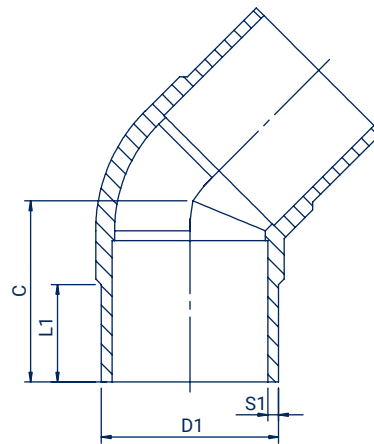

Size D1 (mm)	Code	L1 (mm)	C (mm)	S1 (mm)	Weight (kg)	Packing
63	KD4506317	65	88	3,8	0,15	6
75	KD4507517	71	90	4,5	0,20	24
90	KD4509017	81	104	5,4	0,32	16
110	KD4511017	109	139	6,6	0,67	8
125	KD4512517	94	124	7,4	0,65	6
140	KD4514017	120	168	8,3	1,28	8
160	KD4516017	120	160	9,5	1,54	6
180	KD4518017	107	151	10,7	1,81	3
200	KD4520017	115	164	11,9	2,39	2
225	KD4522517	125	180	13,4	3,40	2
250	KD4525017	137	196	14,8	4,67	2
280	KD4528017	139	218	16,6	6,32	2
315	KD4531517	155	238	18,7	8,44	1