



# SEAMLESS BEND 22°

## SDR 17



water  
10 bar



gas  
5 bar



hydrogen  
5 bar



PE 100-RC  
material



10 MPa



butt  
welding



electrofusion  
welding

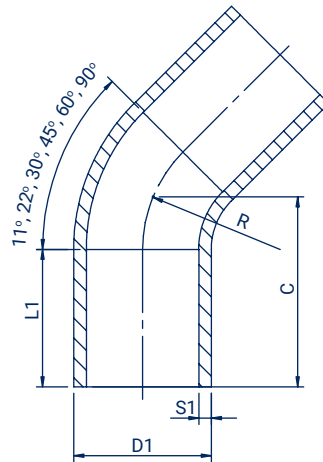

Size D1 (mm)	Code	L1 (mm)	C (mm)	S1 (mm)	R (mm)	Weight (kg)	Packing
63	LU2206317	90	150	3,8	94,5	0,26	1
75	LU2207517	100	155	4,5	112,5	0,36	1
90	LU2209017	150	350	5,4	135	0,98	1
110	LU2211017	120	219	6,6	165	1,12	1
125	LU2212517	150	225	7,4	187,5	1,48	1
140	LU2214017	150	231	8,3	210	1,98	1
160	LU2216017	150	239	9,5	240	2,42	1
180	LU2218017	150	450	10,7	270	5,08	1
200	LU2220017	150	480	11,9	300	6,70	1
225	LU2222517	150	510	13,4	338	9,11	1
250	LU2225017	250	550	14,8	375	11,99	1
280	LU2228017	250	400	16,6	420	12,30	1
315	LU2231517	250	460	18,7	472,5	17,70	1
355	LU2235517	300	540	21,1	532,5	26,00	1
400	LU2240017	300	560	23,7	600	34,00	1
450	LU2245017	300	580	26,7	675	39,10	1
500	LU2250017	350	650	29,7	750	54,00	1
560	LU2256017	350	680	33,2	840	70,30	1
630	LU2263017	350	730	37,4	945	95,80	1