



SEAMLESS BEND 60°

SDR 11



water
16 bar



gas
10 bar



hydrogen
10 bar



PE 100-RC
material



MRS 10 MPa



butt
welding



electrofusion
welding

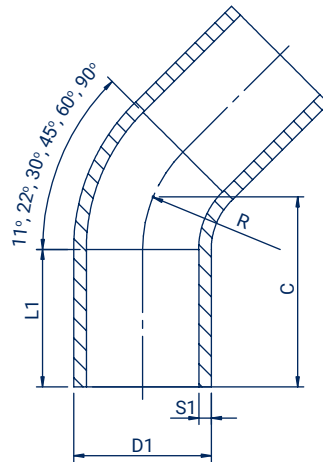

Size D1 (mm)	Code	L1 (mm)	C (mm)	S1 (mm)	R (mm)	Weight (kg)	Packing
32	LU6003211	70	113	2,9	48	0,10	1
40	LU6004011	75	125	3,7	60	0,12	1
50	LU6005011	80	158	4,6	75	0,24	1
63	LU6006311	90	173	5,8	94,5	0,44	1
75	LU6007511	100	182	6,8	112,5	0,60	1
90	LU6009011	260	350	8,2	135	1,28	1
110	LU6011011	240	340	10	165	2,07	1
125	LU6012511	280	390	11,4	188	2,88	1
140	LU6014011	150	296	12,7	210	3,34	1
160	LU6016011	290	430	14,6	240	5,72	1
180	LU6018011	300	460	16,4	270	8,51	1
200	LU6020011	320	490	18,2	300	10,19	1
225	LU6022511	330	530	20,5	338	13,85	1
250	LU6025011	480	700	22,7	375	22,82	1
280	LU6028011	250	530	25,4	420	24,18	1
315	LU6031511	250	612	28,6	472,5	32,80	1
355	LU6035511	300	690	32,2	532,5	41,70	1
400	LU6040011	300	730	36,3	600	55,80	1
450	LU6045011	300	780	40,9	675	76,00	1
500	LU6050011	350	880	45,4	750	116,50	1
560	LU6056011	350	930	50,8	840	139,50	1
630	LU6063011	350	1000	57,2	945	198,00	1