

DRAWING No.:	VERSION	REVISION	REVISION STATUS
REDUCTIONT-PIECE 45DEG PP SIZES	EN	1	ACTUAL

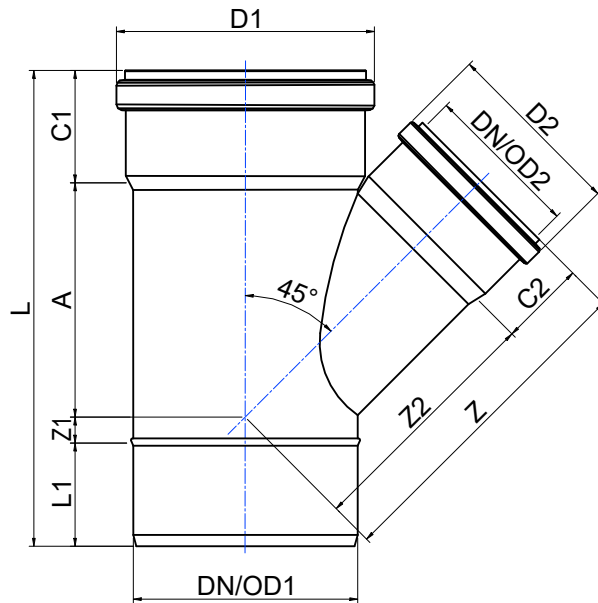

DN/OD1, mm	DN/OD2, mm	D1, mm	C1, mm	D2, mm	C2, mm	L1, mm	Z1, mm	A, mm	L, mm	Z2, mm	Z, mm
Ø160	Ø110	Ø183	75	Ø129	54	75	18	170	338	173	227
Ø200	Ø110	Ø232	100	130	64	117	50	277	544	265	329
Ø200	Ø160	Ø232	100	187,3	84	117	50	277	544	278	362
Ø250	Ø160	Ø290,8	123	186,3	84	144	65	344	676	308	392
Ø250	Ø200	Ø290,8	123	230,6	100	144	65	344	676	333	433
Ø315	Ø160	Ø361,1	146	186,3	84	171	80	435	832	352	436
Ø315	Ø200	Ø361,1	146	230,6	100	171	80	435	832	379	479
Ø315	Ø250	Ø361,1	146	290,8	123	171	80	435	832	412	535
Ø400	Ø160	Ø455,3	173	186,3	84	209	13	405	800	379	463
Ø400	Ø200	Ø455,3	173	230,6	100	209	13	405	800	406	506
Ø400	Ø250	Ø455,3	173	290,8	123	209	13	405	800	439	562



SIA "EVOPIPES"
 Langervaldes str. 2a, Jelgava, LV-3002, Latvia
 Company reg. No.: 50003728871
 Phone: +371 63094300
 E-mail: info@evopipes.lv
 Website: www.evopipes.lv

FILE NAME:
 REDUCTIONT-PIECE 45DEG PP SIZES

SHEET: 1 OF 1

SHEET FORMAT: @A4

SCALE:
 WITHOUT SCALE
 STAGE:
 STANDARD DRAWING